



ibemo Kazakhstan Ltd.

ӨНЕРКӘСІП ЖӘНЕ ЭЛЕКТР МАТЕРИАЛДАРДЫН ЖАБДЫҚТАУШЫСЫ
ПОСТАВЩИК ИНДУСТРИАЛЬНОГО И ЭЛЕКТРИЧЕСКОГО ОБОРУДОВАНИЯ И МАТЕРИАЛОВ
SUPPLIER OF INDUSTRIAL & ELECTRICAL EQUIPMENT and MATERIALS

Tel. +7 (71133) – 93077
Fax +7 (71133) – 93074
E-Mail: info-kz@ibemo.de

INSTALLATION, TESTING and MAINTENANCE

*of Industrial Electric
Heat Tracing Systems*

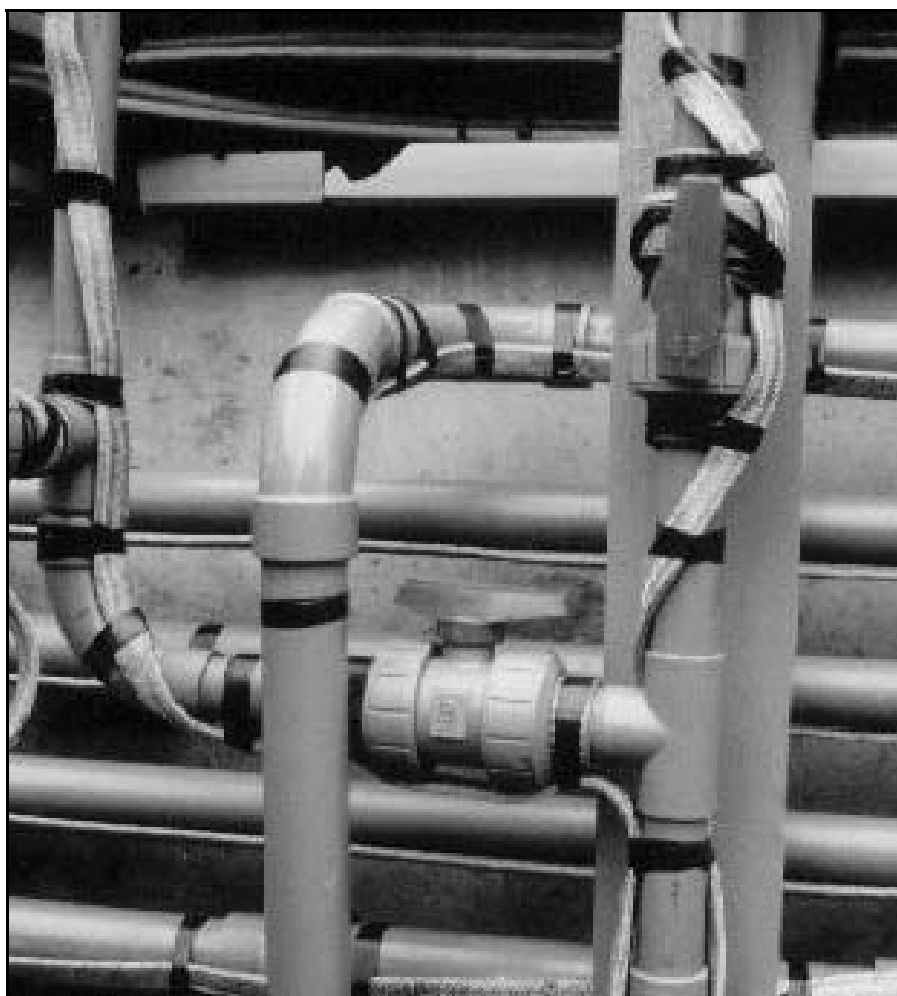

Incorporating
Handling & Shipping
Unpacking & Preservation
Thermal Insulation
Commissioning
Inspection & Maintenance

SECTION G

INSTALLATION, TESTING & MAINTENANCE

Section	Page
Handling & Shipping <i>ESH Ancillaries, Field Mounted Controllers, Control and Distribution Panels, Hook-up Cabling, Cabling Ancillaries, Reception & Storage, COSHH Requirements</i>	G:4
Unpacking & Preservation <i>Transit to Job Site, Preservation, Storage</i>	G:5
Installation <i>Hazardous Areas, Tips for the installer, Pre-Installation, Installation, Site specific, Installation Procedure, Electrical Supply Points, Spiral Pitch, Cable Installtion, Cable Fixings, Flanges, Valves, Cable Terminations, Tee Branches, Plastic Pipework, Sensor Location, Electrical Connections, Earthing / Bonding, Distribution, control and monitoring panels</i>	G:5 - 9
Testing <i>Special Tools</i>	G:11
Thermal Insulation <i>Purpose, System, Properties, Selection of Material, Installation</i>	G:12
Commissioning	G:13
Inspection & Maintenance Testing <i>Operating conditions, Tests on local distribution and control panels, Field mounted components, Heater tests, Insulation resistance testing (all heater styles), Load resistance (constant wattage heaters), Single phase, Three phase, Load resistance (self-regulating heaters), Completion, Repair & Replacement</i>	G:14-15
Installation Test Certificate (QC48)	G:16

Other forms and documents that might be more relevant to a specific application are available from Heat Trace Ltd Head Office.

Examples of alternative forms and documents are shown in Standards BS6361 and IEEE Std.515

HANDLING & SHIPPING

HANDLING

Heater Cables, Guide To Drum Weights & Dimensions

Heat tracing devices are packed on reels. A *guide* to weights and dimensions is given below.

DRUM TYPE		CARDBOARD		HARDBOARD		PLYWOOD		15mm PLYWOOD			
		DIMS (cm)	WTS (kg)	DIMS (cm)	WTS (kg)	DIMS (cm)	WTS (kg)	DIMS (cm)	WTS (kg)	DIMS (cm)	WTS (kg)
		25x16	0.5	43x16	2	75x17	5	100x33	18	100x69	30
HEATER TYPE †	WT. (kg/km)	NOMINAL MAXIMUM METRES AND WEIGHTS									
		(m)	(kg)	(m)	(kg)	(m)	(kg)	(m)	(kg)	(m)	(kg)
FSM	70	-	-	-	-	-	-	-	-	-	-
FSLe, -CT, -CF GTe, FW	42 54 54	200 100 100	7 10 10	300 150 150	10 16 16	- - -	- - -	- - -	- - -	- - -	- - -
FSR, FSP -CT, -CF, HWP	62 147	75 50	5 8	300 100	24 15	600 500	28 43	- -	- -	- -	- -
HWR	147	50	8	100	15	500	43	-	-	-	-
ST, EMTS, EMTF -CT, -CS, -CF	80 143	75 100	8 15	200 150	17 23	500 400	42 62	- -	- -	- -	- -
MTP, MTSS, MTF -CT, -CS, -CF	123 210	50 25	5 9	100 75	12 17	300 200	26 35	- -	- -	- -	- -
HT, AHT, PHT -NF	90 170	50 25	5 5	200 100	29 19	500 250	50 48	- -	- -	- -	- -
HTS, HTS3F -CS	270 434	- -	- -	100 50	29 24	200 165	59 77	500 400	153 192	1000 700	300 334

† Consult the Heat Trace product catalogue for applicable heater options.

Cardboard and hardboard reels are aggregated into cardboard boxes, maximum dimensions 53cm x 47cm x 47cm, for shipment and storage on site. Maximum quantity per 53 x 47 x 47cm box is:-

Cardboard reels 15
Hardboard 3

Esh Ancillaries

Ancillaries are usually individually packaged and aggregated into cardboard boxes, maximum dimensions 53cm x 47cm x 47cm, for shipment and storage on site. Maximum nominal weight: 50kg

Field Mounted Controllers

Field mounted control components e.g.: CAPSTAT controllers and Pt100 RTD sensors plus their associated terminal enclosures are usually individually packaged and aggregated into cardboard boxes, maximum dimensions 53cm x 47cm x 47cm, for shipment and storage on site. Maximum nominal weight: 50kg

Weight of CT 1kg each
Weight of CT-FL 4kg each

Control And Distribution Panels

Control, monitoring and distribution Panels are polythene film wrapped and usually packed into a protective wooden crate for shipment to the job site.

Hook-Up Cabling

XLPE/SWA/LSF or PVC/SWA/PVC hook-up cabling is supplied on industry standard drums, typically 100cm to 150cm diam. x 70cm wide.

Cabling Ancillaries

Cable entry glands, sundries and miscellaneous fixing materials are aggregated into cardboard boxes, maximum dimensions 53cm x 47cm x 47cm, for shipment and storage on site.

RECEPTION & STORAGE

No special facilities are required for receiving goods. All materials should be moved into local secure storage from where they may be taken to site on demand by the installation crews, to minimise pilfering.

COSHH REQUIREMENTS

There are no materials normally supplied by Heat Trace Limited that have any special requirements in respect of Health and Safety. Exceptions will be notified.

UNPACKING & PRESERVATION

UNPACKING

- We recommend that users keep materials in local secure storage within the original packaging until needed at the jobsite. Materials may then be unpacked immediately prior to use. Packaging materials should be taken to the designated disposal point and not be left lying around the site.

TRANSIT TO JOBSITE

- No special equipment will normally be required. Heat tracing devices and ancillaries are usually carried by hand to the point of usage. Local control and distribution panels will be moved and handled depending upon their weight, like any other control panel or distribution board.
- Heat tracing units should be kept wrapped on their delivery drums or reels until needed at the work site. They should not be stacked more than 3 high. Keep clear of sharp objects, welding operations, or any other activity which puts the outer jacket of a flexible heater at risk from mechanical damage.
- Manoeuvre control and distribution panels carefully into their final position taking great care not to scratch or otherwise damage the paint finish, viewing windows, handles or other exposed parts.

PRESERVATION

- No special preservation regime need be imposed. The original packaging if kept dry and intact will prove sufficient.

STORAGE

- Store in clean and dry conditions unless the equipment clearly has been packed for sea freight as deck cargo e.g.: polythene wrapped with desiccant and contained within a solid wooden case when it may be stored in open sided but covered areas. Termination kits containing silicone rubber sealant (RTV) should be stored at temperatures below 25°C (77°F) or consumed within 6 months of shipment.

INSTALLATION

GENERAL

- Installation of electric surface heating devices should be in accordance with BS7671 (IEE Wiring Regulations), BS6351:Part 3: Code of Practice for the Installation, Testing and Maintenance of Electric Surface Heating systems, or American Standards ANSI:IEEE515 and 515.1: Testing, Design, Installation and Maintenance of electrical resistance Heat Tracing, whichever is the most convenient to local practice, supplemented by any site specific instructions).
- Only suitably trained personnel should be employed in the installation and testing of electric heat tracing systems. A trained supervisor should be in attendance at all stages of the work, particularly for installation in hazardous areas.
- Refer to the appropriate product data sheet and termination instructions for additional information.

HAZARDOUS AREA

- Special considerations pertain to installations in potentially explosive atmospheres, eg. In addition to the requirements of the DIN VDE 0100 series, DIN VDE 0721 Part 1 and DIN VDE 0721 Part 2A3 shall also be complied with where used in industry. Further detail may be found in the referenced Standards or from the Heat Trace Contracts Department.

TIPS FOR THE INSTALLER

A. Pre-Installation

Before starting the installation phase:

- Check that you have adequate sketches or drawings to define the scope of the heat tracing work and the correct type, style and voltage of the heaters.
- Walk the system and plan your routes.
- Measure out the lengths of pipework to be traced and/or check the dimensions of tanks and vessels to ensure that they are those as shown on the drawings. If not, then contact the supplier or design office for further instructions before proceeding.
- Ensure that the surfaces to be heated are fully tested, free for use and free from any sharp edges, weld splatter, cement splashes or other substances which could damage the sheath of the heaters.
- Check with the client to confirm the arrangements made for applying the thermal insulation. This work must be co-ordinated to minimise the risks of mechanical damage to the heaters whilst the surfaces are open and unprotected by lagging.
- Fix and mark the position of all circuit supply points and thermostat sensor locations, paying particular attention to the location of any over-temperature devices in the system.

- Fix and mark the position of any special arrangements to be made to absorb differential expansion (eg. LONGLINE systems)
- Check that the equipment corresponds to the system design specification, in particular with the client. Check that expected exposure temperatures are within the exposure range of the heaters.

B. Installation

Installation work may now start considering the following:-

- Keep the tracer, as far as is reasonably possible, in good contact with the surface to be heated (to maximise system efficiency.)
- Overlapping of the heaters is not good practice and should be avoided always. Constant wattage heaters should never overlap without special dispensation from the System Designer.
- Always follow any instructions written on the heater tape regarding which face should be toward the pipe and which face should be away from the pipe. (Some heaters have an asymmetrical configuration).
- All pipework supports should be in place. Cut suitable slots in insulated supports if not already provided. Pipe supports must not be retro-fitted on top of heating tapes or cables.
- If the location would cut or crush your fingers in service then its not a good place to put a flexible heater.
- Always use the recommended fixing tape particularly with stainless steel surfaces. Use of non-recommended fixings may invalidate product warranty.

Site Specific

For site specific details, refer to project detail drawing.

INSTALLATION PROCEDURE

ELECTRICAL SUPPLY POINTS

Locate all the electrical supply points (and where applicable, any splice connection points) and site the components into which the heaters will be terminated. Any associated thermostatic controls or sensors should also be fixed and, if appropriate, intertwined to the power supply unit. Fittings normally are mounted onto predrilled Heat Trace pipe mounting brackets or to any other firm surface within ½m of the termination (design) point.

SPIRAL PITCH

If the tracer is to be spiralled onto the pipe then follow the circuit route, marking off the required spiral pitch with a piece of chalk. *It may help to apply string or cord to the specified spiral ratio and note the resultant spiral pitch before applying the heaters.* If the same pitch is commonly in use then a stick or rod marked with the spiral pitch may be a useful gauge.

CABLE INSTALLATION

Follow the specific termination instructions. Generally they suggest cutting a zonal tracer close to an electrical zone connection which will be just visible through the basic tracer sheath. Series heaters must equal the design length when installed.

Starting adjacent to the supply point, anchor the tracer to the surface with fixing tape at the next electrical connection (zonal tracers) or approximately ¾ metre distant with other types, leaving the remainder of the tracer freely suspended for making off the terminations.

CABLE FIXING

Spiral or straight trace as indicated on the drawings, following any instructions concerning which face is to the heated surface. Apply straight tracers to the lower half of the pipe if possible, keeping away from the underside of flanges and other joints which might leak fluids onto the tracers in service. (See Fig 1).

Keep the tracer rolled up as far as possible and apply under SLIGHT tension. Fix straight traced heaters every 300mm (12") with 1½ turns of fixing tape. It is recommended that an expansion allowance for all nominally straight traced heaters is allowed. This is achieved by a turn around the pipe at regular intervals, or by special expansion conduits applied to larger pipes. In no case should fixings be applied at more frequent

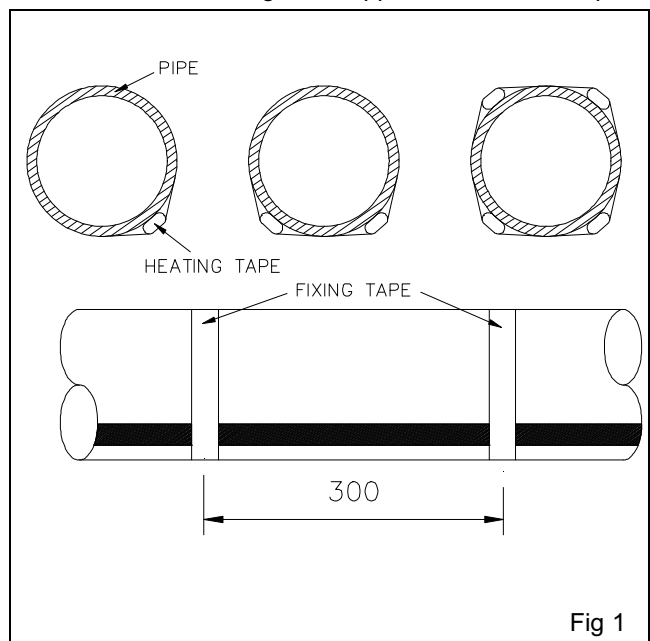

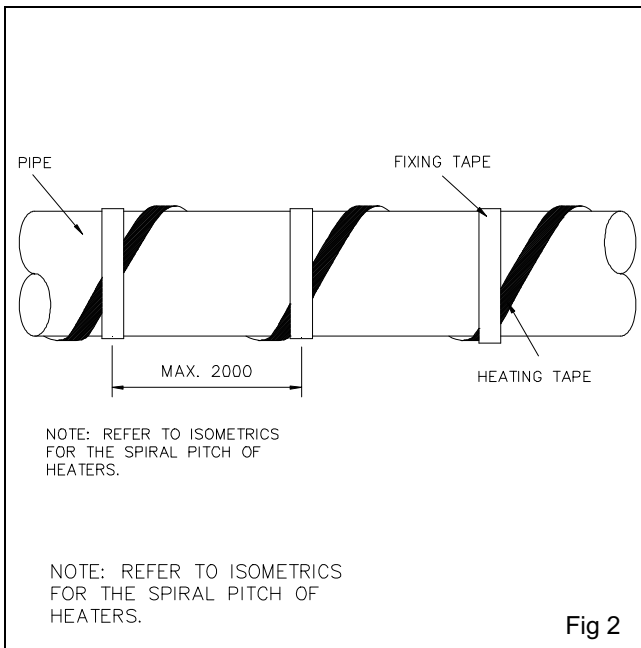

intervals than the 300mm recommended in most standards, eg. wrapping fixing tape in a continuous close spiral over the tracer is not good practice and may result in expansion failures near the mid-point of the circuit. It is sufficient to fix spirally applied heaters at 2m (6ft) intervals.

Heaters normally are spiralled only to a maximum ratio of 1.5:1. Greater ratios would be met by multiple straight tracing unless otherwise specified by the system designer. (See Fig 2).

FLANGES

At flanged joints, ties should be positioned on either side and close to the flanges to ensure maximum surface contact. To avoid mechanical damage during future servicing of the line fitting, and to cater for additional heat losses, allow sufficient slack, generally as a small loop over the flange, to permit attention to the flange packings. To avoid damage from leakage do NOT pass the tracer over the flange at the 6 o'clock position. (See Fig 3).

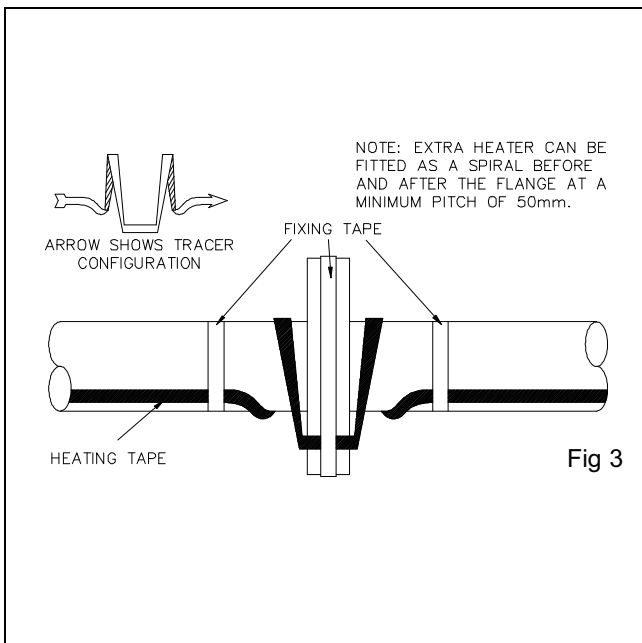

VALVES

If valves are not to be provided with separate heaters then allow sufficient extra heater to cover the additional losses. Appropriate allowances are suggested in BS6351:Part 2:1983 - Design of Electric Surface Heating Systems or may be marked on the system drawings. Heat tracers should be "reverse spiralled" at fittings to permit future withdrawal of the fitting for service. (See Fig 4).

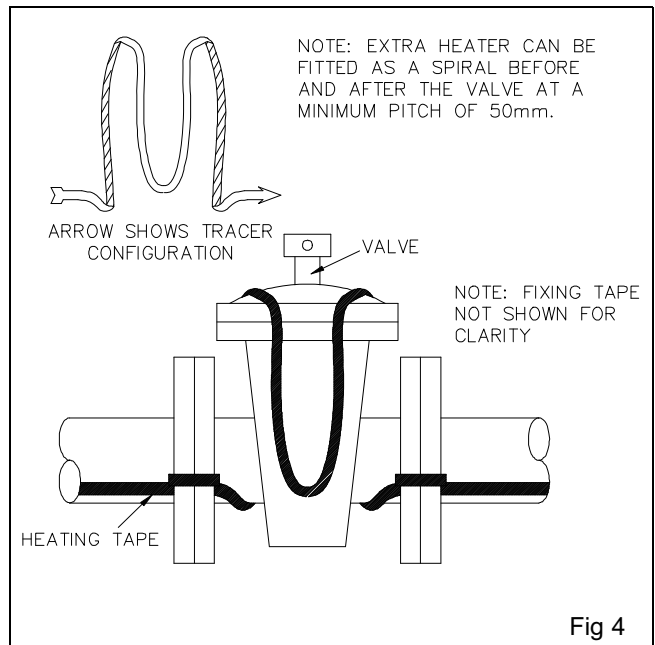

Heating tape should always follow the long radius at bends. (See Fig 5).

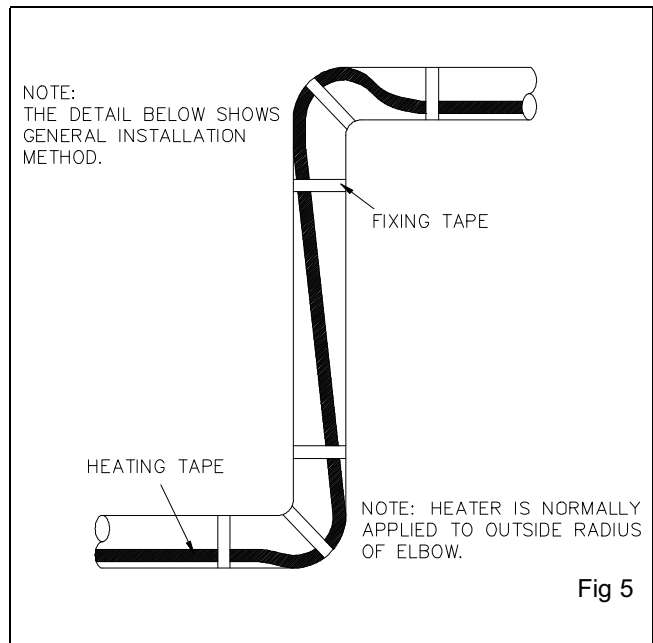

CABLE TERMINATIONS

Terminate the tracers and fit the end seals in strict accordance with the product specific instructions.

Do not connect together the conductors of a parallel circuitry heater because this results in a short circuit.

Protect all cable ends from moisture, damage or other interference if they are to be left exposed for a protracted period.

SPLICE CONNECTIONS

To facilitate the removal of spool pieces or fittings without disturbing the tracer scheme, parallel circuitry tracers may be cut at flanges, filters, pumps, etc. and a splice connection made off into a suitable junction box.

Note:

It may be possible to use this technique with series heaters by substituting lengths of suitably sized hook-up cable to a maximum total of 5% of the original circuit length.

TEE BRANCHES

At tee branches the tracer may be cut and the three sections from each branch be spliced together using a splice kit (if available) or termination kits and a tee connection box. Alternatively it may be more convenient to trace through the Tee position and provide an independent tracer for the branch. (See Fig 6).

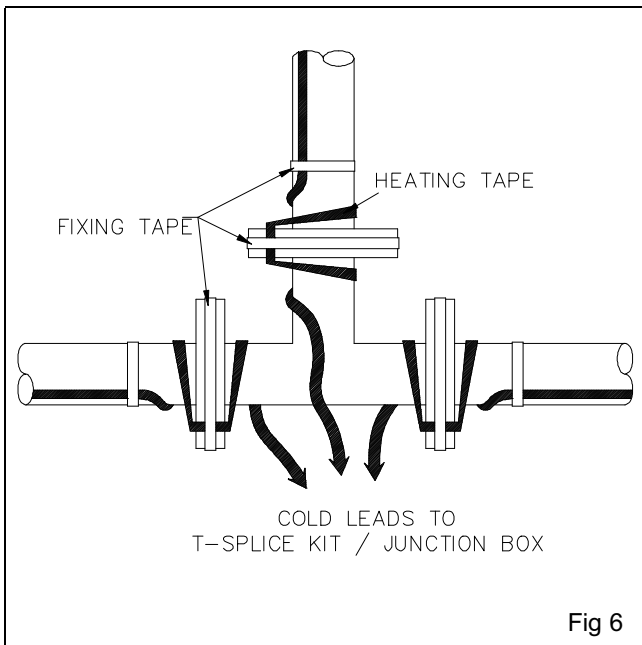

PLASTIC PIPEWORK

Plastic piping always will use low power heaters, usually applied over a metallic foil carrier or fixed with an adhesive backed metallic foil tape.

SENSOR LOCATION

Position the sensor of the thermostat or other controller on the heated surface within 100mm of the heater using fixing tape, special adhesive backed aluminium fixing tape, or heat resistant clips. The temperature sensor should not be in direct contact with the heater unless the heated surface is plastic when it should be placed immediately adjacent to the heater. Set the thermostat or other controller to the design operating temperature specified in the system drawings or documentation. (See Fig 7).

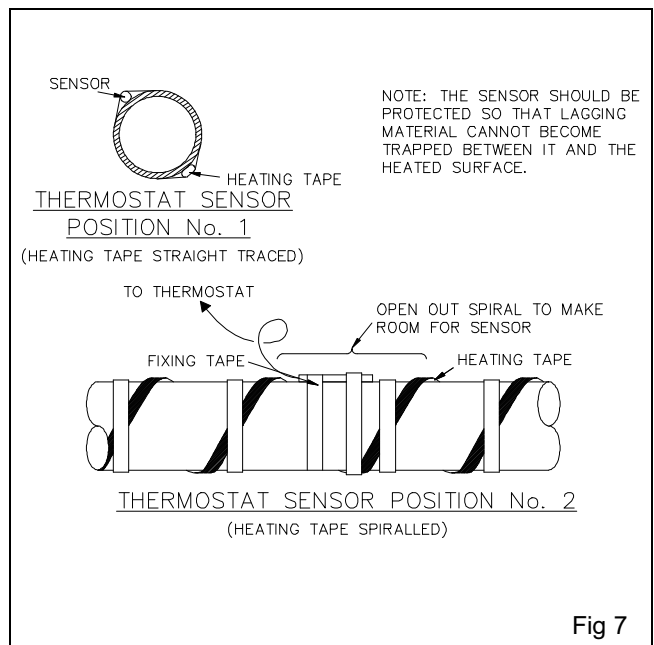

FITTINGS

Typical application of trace heating at fittings:
Heater installation around strainers (See Fig 8)

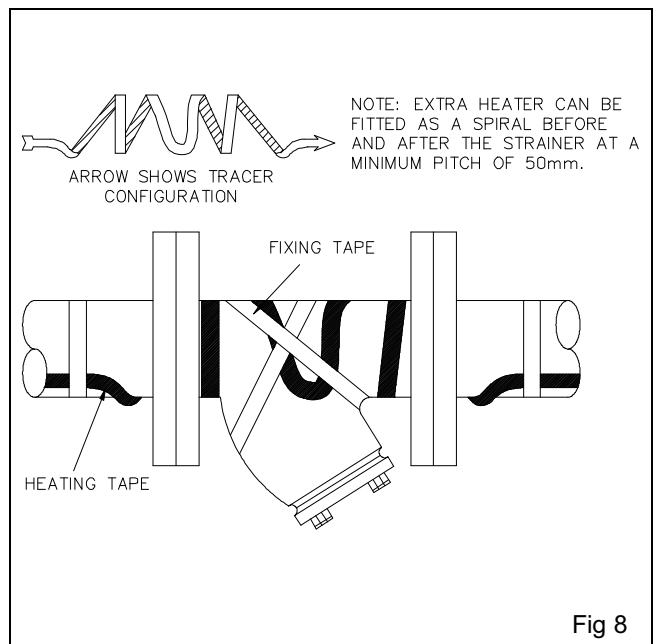

Pipe supports (See Fig 9)

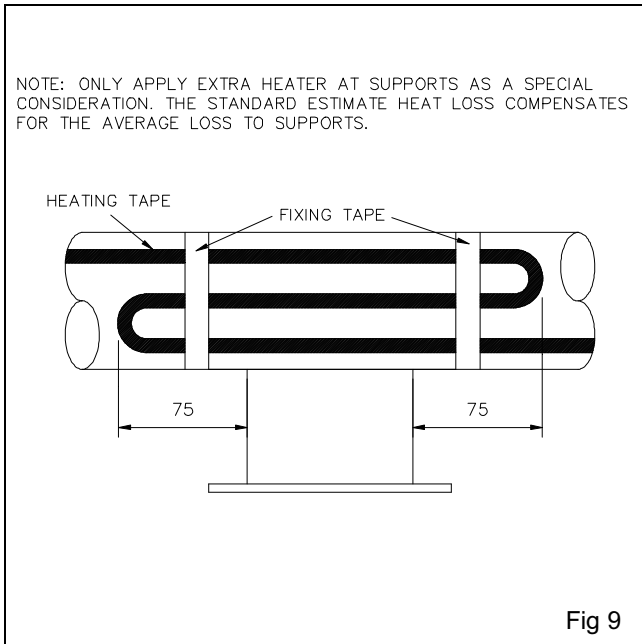

Pumps (See Fig 10)

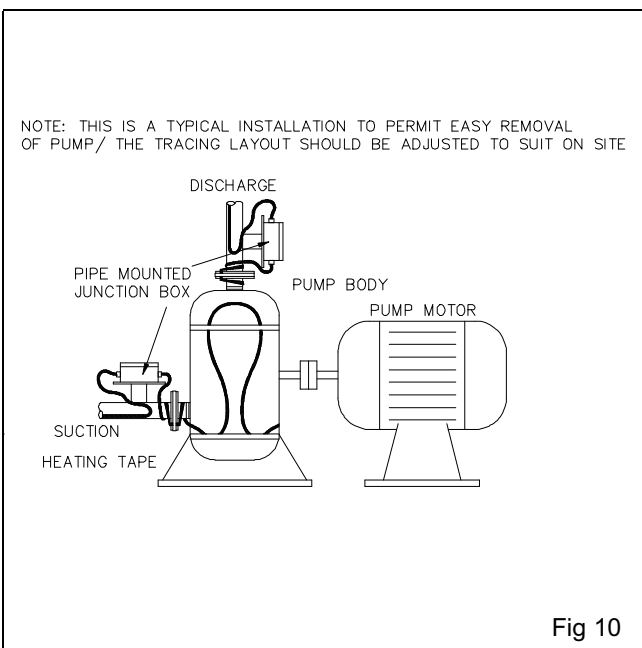

ELECTRICAL CONNECTIONS

Make off the electrical connections into the termination units. Ensure that any interwiring between thermostats and power supply units is complete (see ELECTRICAL SUPPLY POINTS above).

Note:

Electrical hook-ups, and interwiring of heat tracing components often are the responsibility of the main electrical contractor and so may not be a part of the heat tracing installation.

EARTHING / BONDING

Before putting into service, earthing/bonding must be in accordance with BS7671, or DIN VDE 0100 Part 410. Check that provision is made as appropriate for all extraneous metalwork eg. external metal braids or mounting plates to be connected to the installation's main earthing terminal or are bonded to protective conductors.

Particular attention should be paid to bonding the sheaths of mineral insulated metal sheathed cables because, under fault conditions heavy earth currents from associated installations could be present.

Note:

A label must be firmly attached in a visible position at every point of connection of every conductor which bonds extraneous conductive parts. (See Fig 11)

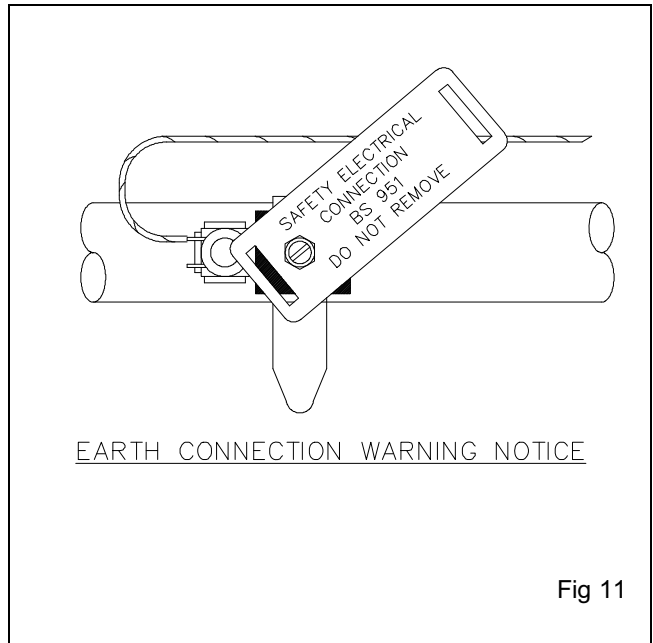

Distribution, control and monitoring panels

○ *General*

Control and monitoring panels (often referred to as “Local Distribution and control Panels”, or “LDP’s”) are held in secure storage until required at the job site. They are then moved with proper care and attention and unpacked close to the point of final installation. Installation is normally to a convenient wall or as independent floor mounting units. Panels are finally positioned taking care not to damage the finished surfaces, and secured with suitable bolts to the wall, floor or other supporting structure.

● *Electrical protection and In-rush currents*

Back up fuse or miniature circuit breaker (MCB) protection should exist for each circuit, rated for the cold start current on the heater. *For constant wattage heaters this is usually the same as the run current. Self regulating heaters exhibit inrush depending upon the cold start temperature. This may be many times the normal operating current of the heaters.* For this reason it is important to select an appropriate cold start temperature. For example, freeze protection of cold water pipes against a minimum ambient of -15°C will be designed for heat loss at -15°C, but is unlikely to be started below +5°C.

Earth leakage circuit breakers should always be installed where possible (mandatory in hazardous areas). *30mA trip rating is preferred.* Variable rated RCD’s (Residual Current Devices) may be required for LONGLINE systems.

● *Making off Connections*

If included in the scope of work, the cabling to and from the control panels should be installed up to the panel without making the final connections. If connections are to be made to the panel terminals, then a qualified person must test all cables for continuity and insulation resistance before proceeding further. Only after satisfactory completion and RECORDING of all tests may the final connections be made off.

TESTING

See also 'INSPECTION & MAINTENANCE TESTING'.

SPECIAL TOOLS (INSTRUMENTS)

The following are required:-

- A standard multimeter for the measurement of circuit resistance.
- A 500V DC insulation resistance tester e.g.: "Megger" tester for systems to 500V in accordance with BS7671 (IEE Wiring Regulations).

GENERAL

Heating tapes should be inspected and tested at three stages:

- i. on receipt at site - continuity & in-transit damage

Continuity & Insulation Resistance

- ii. after installation
- iii. after application of thermal insulation.

Insulation resistance tests

After completion of the heater installation phase, the insulation resistance between the power conductors and the heater braid or metal pipe should be checked (0.1M Ω .km to a minimum of 10M Ω)

Complete all site RECORD drawings and Test RECORDS (see sample Form QC68). If the results of any checks are not understood or not acceptable, no further work should proceed until the query has been investigated and clarified or rectified.

Note:

- i. CONSTANT WATTAGE tracers of any type should be checked for correct installed resistance.
- ii. Series resistance LONGLINE heaters are temperature dependent and so resistance readings will vary with the prevailing temperature condition. Any resistance readings must be accompanied by a simultaneous reading of workpiece temperature and ambient air temperature.

- iii. SELF REGULATING (semi-conductive) heaters are temperature dependent and resistance readings are not a reliable guide to the installed load. For this reason self-regulating heaters usually are checked only for insulation resistance to earth.

Verify that all control and monitoring circuits are fully functional. A bypass may be required at field contacts.

Before making connections to the distribution or control panel, confirm that satisfactory meter TESTS and RECORDS exist for all circuits, checking for continuity, insulation resistance and correct electrical connections.

FAULT FINDING & TESTING

Fault finding table, Heaters

The following table may be helpful in establishing the most likely causes of operational problems:-

FAULT	POSSIBLE CAUSES
No current	Supply switched 'OFF' or failed Fuse blown, RCD / MCB tripped Open circuit cable termination Open circuit hook-up cable Open circuit heating unit termination Over temperature switch operated Thermostat Failure (to open circuit)
Low current	Unit disconnected within a multi-heater section Internal fault in heater Low supply voltage Loose contacts - causing high resistance in series with load.
High current	Internal fault in heater Arcing across terminals High supply side voltage
RCD no trip (on test)	No supply to RCD Internal fault
RCD no reset	Earth fault on long circuit output Charging current on or distant load - TRY SEVERAL RESETS Internal fault

RECORDS : All test results should be recorded as a part of the system documentation (see sample Form QC68)

THERMAL INSULATION

PURPOSE:

Dry and efficient thermal insulation is fundamental to any heat tracing scheme. Heat tracing only makes good the losses from the thermal insulation i.e: it makes the lagging 100% efficient.

The thermal insulation system has a quadruple function:-

- 1) reduction of heat loss to an acceptable economic level
- 2) reducing "touch" temperatures to a safe level
- 3) providing a stable and predictable rate of heat loss that can be calculated and replaced by electric heat tracing.
- 4) providing mechanical protection for the heating devices.

SYSTEM:

The thermal insulation system comprises two or more layers:-

- 1) the thermally insulating material over the heaters
- 2) a vapour barrier over the lagging material
- 3) an outer weatherproofing or abrasion resistant layer

Layers 2) and 3) may be combined.

PROPERTIES:

The use of thermally insulating materials on above ground pipes and vessels is embraced by British Standard BS5422:1990 with underground systems being covered by BS4508:1977. The content of these Standards is applied to Heat Trace Ltd software used in the design of Electric Surface Heating Systems to BS6351:1983:Part 2, ANSI:IEEE515 and other National or international Standards.

SELECTION OF MATERIAL

Thermal insulation must be selected to withstand the maximum surface temperature of the heater which often is higher than the maximum process temperature. Particular care is needed in the use of foamed plastic insulants.

INSTALLATION

General

- To minimise the risks of damage to heaters, suitable thermal insulation should be fitted as quickly as possible after completion and testing of each electrical heat tracing circuit. If the thermal insulation work cannot be completed within the working day then well fixed temporary cover and protection should be applied to the heating components
- Before installation of the thermal insulation material restarts, electrical checks should confirm that no damage has occurred.

Code of Practice

The installation of the thermal insulation will be in accordance with Code of Practice BS5970:1982 or other relevant Standards.

MARKING

- BS6351:Part 3 requires "Caution - Electric Traced" labels to be fitted at a maximum of 6m intervals.
- The location of any components concealed beneath the insulation should be marked on the outer cladding.

Site RECORDS

- Check and RECORD that the thermal insulation material is suitable for the hot face temperatures concerned and is to the designed thickness.
- Recheck and RECORD the heater circuits for continuity and insulation resistance after the thermal insulation has been completed and confirm that the temperature sensors are still firm, in the right place and that electrical connections are still valid.

CAUTION: IF ANY WORK IS UNDERTAKEN WHICH INVOLVES THE REMOVAL OF THERMAL INSULATION - ESPECIALLY REMOVABLE FLANGE AND VALVE BOXES - THE GREATEST POSSIBLE CARE MUST BE EXERCISED. METALLIC CLADDING CAN VERY EASILY CUT OR TEAR THE OUTER INSULATION OF ANY FLEXIBLE HEATING TAPE OR CABLE. NO SHARP METALLIC EDGE SHOULD BE ALLOWED TO COME INTO CONTACT WITH THE HEATERS AT ANY TIME.

Protecting Cable Entries

Heat Trace Ltd provide a number of accessories to minimise the possibility of damage to heating tapes and cables when passing through the thickness of thermal insulation. These range from DESTU mountings for FREEZSTOP products, to LEK/U universal lagging entry kits - see product data sheets.

COMMISSIONING

Commissioning usually is limited to ensuring the accuracy of site records, the electrical safety of the heating installation and any control or distribution package. Provision of a mains supply, energisation and neat proving runs usually lie outside the scope of the heat tracing contract.

For site specific details refer to the project detail drawings.

- Ensure that all drawings and test certificates (see HTL sample Form QC68) are to hand.
- Ensure that the heated surface, pipe, tank or vessel, is properly connected to the installation's main earthing terminal or is bonded to protective conductors which will be at or near earth potential under fault conditions, using a conductor sized as the main earth conductor to a minimum of 4mm² cross sectional area.
- If not already completed or if several days have elapsed since the RECORDS were entered, recheck and RECORD the heater circuits at the point of electrical supply for continuity and insulation resistance following installation of thermal insulation. Check that junction boxes are free of water and lids secured.
- Confirm that the temperature sensors are still firm, in the right place and that electrical connections are still valid.
- Check and RECORD that temperature control (thermostat) units are fully functional and that settings are correct and accord with the design drawings. *For frost protection duties it is usual to control several or all circuits from an air temperature sensing thermostat set at +6°C (43°F).*
- Check and RECORD that the thermal insulation material is suitable for the hot face temperatures concerned and is to the designed thickness.
- Fit warning labels in prominent positions to the outside of the thermal insulation covering at intervals not exceeding 6 metres (20 feet) to indicate the presence of HEAT TRACE flexible electrical heaters beneath the surface.
- Check the correct operation of any circuit health monitoring devices.
- Check that all lamps and indicators are functioning and associated with the correct heater circuit.
- Check and RECORD that the back up fuse or MCB protection is correctly rated and the lowest possible size consistent with the circuit characteristics. Where residual current devices (RCD's) are employed, test for correct operation and that Warning Notices are in place.
- If part of the heat tracing contract, check that all power and control cabling is correctly sized, in the right sequence and in good order.
- Complete all permanent tagging, labelling and identification e.g. heater power connection labels, thermostat number and set point, caution and warning labels.
- **ALL RESULTS SHOULD BE RECORDED TO FORM PART OF THE SYSTEM DOCUMENTATION.**
- ***A CERTIFICATE OF COMPLETION should be issued upon satisfactory completion of the commissioning procedure.***

INSPECTION & MAINTENANCE TESTING

GENERAL

Routine visual inspection for damage or defects in the thermal insulation system or its weather barrier inspection is recommended. If damage or defects are found, remedial work should be put in hand after inspection of the associated electrical circuit.

Periodic checks should be carried out at least once a year. For frost protection systems this work is conveniently scheduled in the late summer. More frequent and/or more detailed inspection may be necessary, depending on the criticality of the heating system to successful plant operations, in corrosive or other hostile environments or where there is a high risk of mechanical damage.

“As Installed” drawings and test certificates should be to hand during the following checks:-

OPERATING CONDITIONS

- Ensure that the maximum service temperature is within that permitted for the heater tape or cable and any associated controllers. EXCEEDING THIS LIMIT MAY RESULT IN PERMANENT DAMAGE.
- The thermal insulation must be complete and dry if the correct temperature is to be maintained.

TESTS ON LOCAL DISTRIBUTION AND CONTROL PANELS

Isolate the incoming supply. Check and RECORD the following:-

- Correct operation of RCD's and the presence of statutory Warning Notices.
- Correct operation of MCB's
- Correct settings and operation of all temperature responsive controllers.
- Correct operation of any Circuit health monitoring devices.
- All lamps and indicators in working order.

The correct operation of individual HTL control and monitoring devices may be assured by following specific Site Setting Up Procedures.

FIELD MOUNTED COMPONENTS...

- Temperature sensors are securely affixed.
- Junction boxes are free from ingress of water and with terminals secure and in good condition.
- Power and control cabling is in good order.
- Thermal insulation is clean, sound and dry.

HEATER TESTS

Disconnect heater circuits in the distribution board or panel.

Refer to the TEST SHEETS (see HTL sample Form QC68). See also 'TESTING'.

Test 1 - Earth Faults at the distribution or control panel

Insulation Resistance Testing, all Heater Styles

Use a 500V DC insulation resistance tester (“Megger”) between live and/or neutral connection and earth for each heat tracing sector. A steady reading of 0.1MΩ.km (typically around 200 Megohms should be attained. Each section of heating tape should be tested individually.

Typical causes of low insulation resistance readings include ...

- Cold lead-ins to heaters damaged in the junction box or where the heater passes through metallic cladding to the thermal insulation.
- Water inside a terminal box.

Test 2 - Load Current Faults

A. Load Resistance, Constant Wattage Heaters

Use a multimeter or similar digital ohmmeter and cross refer to Test Sheet Data.

A.1 Single Phase System, Parallel Circuitry

- Test between live and neutral connections of the heater circuit. Compare this reading of total load resistance with that obtained at commissioning and shown on the Test Certificate. If there is more than 10% difference in the figures, suspect a fault in the heater sector components. Subdivide each heating sector into its component parts i.e.: individual heaters. Repeat by testing each one in turn, comparing the individual load resistance to the value shown on the Test Certificate and/or heater label and/or drawings.

A.2 Three Phase System, Series Circuitry

- Test between the conductors with the star point made. Phase to phase readings should be balanced.

Note:

Variations in resistance up to 10% on “constant wattage” heaters probably do NOT indicate a fault but will be the result of several system variables, including, but not limited to:-

- the temperature coefficient of resistance of copper busbars within the heating devices.
- a difference in the accuracy or calibration of your meter and the meter used to measure the original load resistance's.
- lead resistance on your meter.

B. Load Resistance, Self-Regulating Heaters

The resistance of self regulating heaters depends on their core temperature. It is not practicable to rely on resistance readings on site. Any such readings must also RECORD the pipe wall and prevailing ambient temperatures at the time of measurement. The only useful measure of performance is the product of volts and amps after sufficient time has elapsed to reach an equilibrium (temperature dependant) condition.

COMPLETION

Reconnect heater circuits in the distribution board or panel and re-energise the heating system.

REPAIR AND REPLACEMENT

- Do not make repairs to a damaged heater. Remove the affected section and splice in a replacement length using the appropriate jointing method.
- Replace any damaged cable without delay.
- Do not re-use until circuit has been fully restored and satisfactorily tested.