

HEAT TRACING OF ABOVE GROUND LONG PIPELINES



THE APPLICATION

Installed Electrical Loads

Heat losses from above ground pipes vary directly with ambient temperature. The installed power must be able to compensate for losses at the lowest potential air temperature – which may never actually prevail.

The excess heat which is virtually always available can result in system failure or reliability problems.

Electrical Supplies

Often the most important consideration when heating long pipelines is the number and location of electrical supplies. They are normally available only at the pipe ends. The cost of providing intermediate supplies is prohibitive, so heating circuits must be designed for long route lengths.

The Need for Power / Energy Management

Long pipelines typically require hundreds of kilowatts to maintain pumpable temperatures. Power/Energy management minimises operating costs, maximum demand and eliminates expansion/contraction which could result in failure of the thermal insulation or heater.

Reliability

Failure of a multi-kilometre heating circuit renders the complete pipeline useless. Thus, system reliability and life is much more important than for in-plant heat tracing.

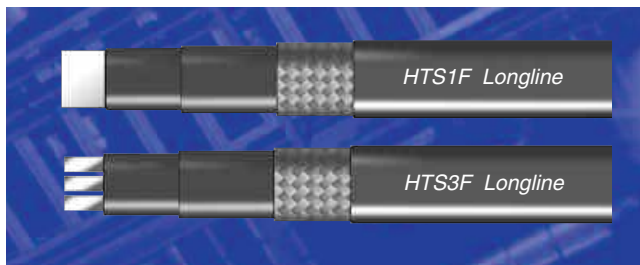

HEATING CABLES

Low resistance conductors, 3 phase star connected produce long circuits. Conductor sizes and applied voltage are adjusted to provide the required length and output.

A single *Longline HTS3F* tracer having 3 conductors is suitable for shorter circuits (up to, say, 1km). Multiple large single conductor *Longline HTS1F* tracer cater for longer circuits (up to, say, 5km).

Compared with round conductors, flat foils are outstandingly thermally efficient due to their large surface area and they are much more flexible.

Conventional Control

Long heated pipelines are usually controlled by a line thermostat operating a large contactor having a limited life – a 20 minute ON/OFF switching cycle may result in contact failure in less than two years.

To extend contactor life, the thermostat switch differential is often widened to reduce the switching frequency. This produces poor efficiency under no flow conditions. When the product flows, energy wastage is 100% because the controller switch off temperature is never reached and so the load remains permanently energised.

ON/OFF thermal cycling of the piping and its system eventually results in, at best, damage to the thermal insulation system and possible system failure.

For a high integrity long pipeline installation, this form of control is inappropriate.

Powermatch Control

By always varying the heat output to match losses which vary with air temperature, thermal cycling is removed – significantly increasing heater life.

Similarly, the absence of a switching differential reduces energy usage by as much as 75%.

In an Energy Efficiency Office Demonstration Project, a *Powermatch* was retrofitted to an existing long pipeline heat tracing installation which used a conventional capillary line thermostat. In the same project, a *Durastat* proportional line controller was fitted to an adjacent circuit. This experiment demonstrated energy savings of 67% and 70% respectively.

Combining the self-regulating *Powermatch* with a *Durastat* fine tune line control is expected to increase savings to 75%. A standard *Powermatch* unit now incorporates both control functions.



HEAT TRACING OF ABOVE GROUND LONG PIPELINES

INSTALLATION EXAMPLE

A 36" x 1925m long, heavy fuel oil pipeline, above ground.

Electrical feeds	at pipe ends only
Maintain	60°C
Minimum ambient	-10°C
Maximum ambient	+40°C
Heat raise facility	10 – 60°C in 27 hours
Maintain load	80W/m at minimum ambient
Heat raise load	120W/m
Installed load/circuit	115.5kW
Voltage	480V 3ph
Operating current	139A/ph

The *Powermatch* is programmed to deliver 80W/m ($\frac{2}{3}$ of installed load) at the minimum ambient temperature. An override applies full power for heat raising with automatic switch back to the maintain load on reaching the set-point.

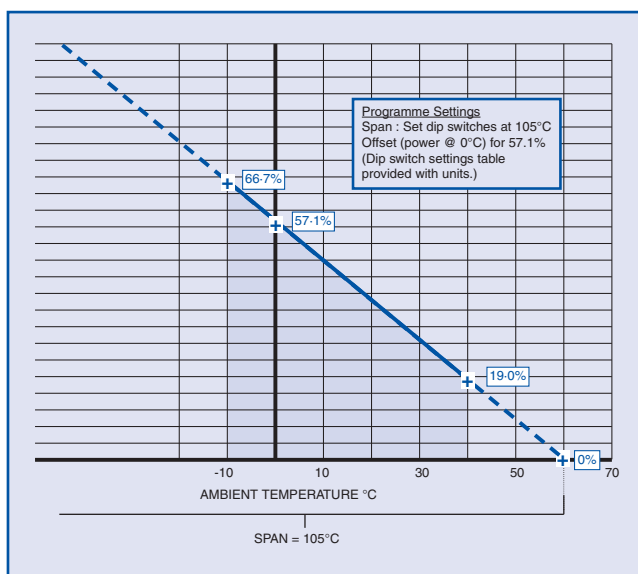

SUMMARY

Three heaters are applied to the pipe, each producing 40W/m. From the graph, it can be seen that under normal temperature maintenance conditions, the three heaters deliver between only 19% and 66.7% of their rated output (7.6 to 26.7W/m) without thermal cycling. Heater life expectancy would be virtually infinite.

Circuit health monitoring provides time in which to correct any damage before line temperatures fall to an unacceptably low level.

Energy consumption/operating costs and maximum demand are minimised.

TYPICAL CONTROL ARRANGEMENT

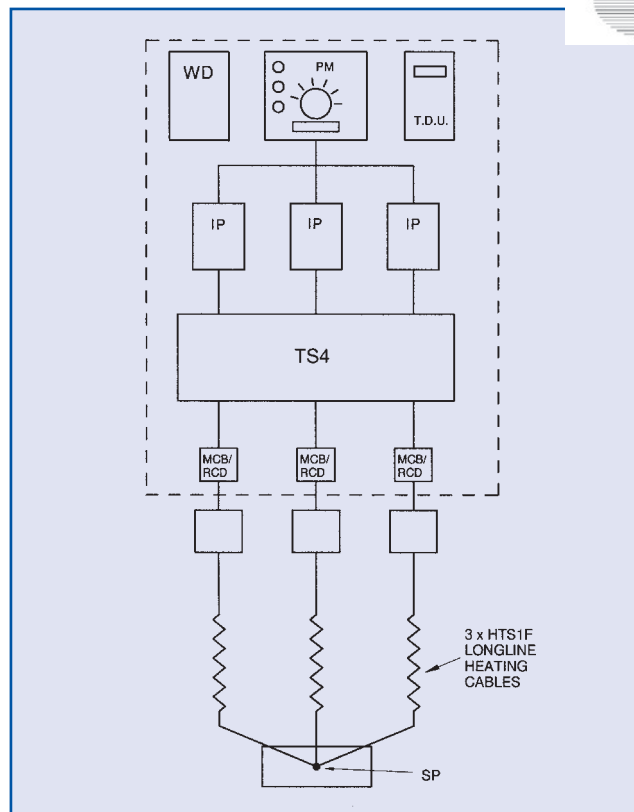

PANEL FASCIA (dimensions in mm)

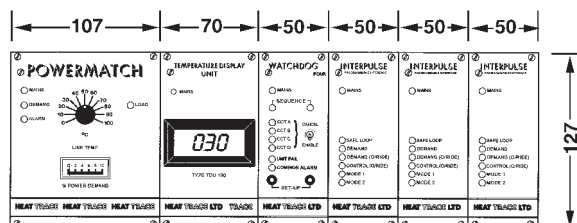

KEY

WD	Watchdog circuit health monitor	CPDS070
PM	Powermatch self-regulating controller	CPDS030
TDU	Temperature display unit	CPDS050
IP	Interpulse drive interface unit	CPDS040
TS4	Thyristor stack	CPDS130
SP	Star point	N/A